

# CCK30662AF

## 1/2.8" High Sensitivity 2M CMOS x30 Zoom/AF Camera Module



### ■ Overview

- 2M camera module equipped with SONY Startvis2 color image sensor.
- Equipped with 1/2.8" 30x optical zoom lens for 2M.
- Adoption of compact size housing.

### ■ Feature

- Near-infrared sensitivity is greatly improved compared to conventional sensors, and when combined with near-infrared light, surveillance images at night become clearer.
- Supports auto ICR operation, automatically switching from daytime color images to nighttime near-infrared images.
- Due to Binning mode, the maximum sensitivity is more than doubled compared to Normal.
- 30x optical zoom and 15x digital zoom for a total of 450x zoom.
- Equipped with auto iris, auto electronic shutter, auto gain, auto white balance, and auto focus.
- Equipped with various correction functions according to the image scene (DNR, WDR, fog, heat haze, etc.).
- Supports TMDS output and easily converts to HDMI.
- Supports EX-SDI/3G-SDI/HD-SDI output, enabling long-distance wiring up to 400m without image quality degradation.
- Supports 1080p, 1080i, 720p video formats.
- Flexible support for additional functions.

**Global Chip Technology Corp.**  
2-9-4-6F, Maruei-No.6 BLDG.  
Minami-cho, Chuo-ku, Chiba-Shi  
Chiba-Ken, Japan 〒260-0842  
TEL : +81-43-308-6300  
FAX : +81-43-261-6100  
E-mail : info@gct-c.com

## ■ Specifications

Sensor	Image Sensor	1/2.8" SONY CMOS Image Sensor (IMX662-AAQR1) Starvis2 for NIR
	Number of pixels	1936(H) x 1120(V), 2.13M Pixels
	Pixel Size	2.9 $\mu$ m(H) x 2.9 $\mu$ m(V)
	Scan Format	1920x1080@60/50/30/25fps (Option 1920x1080@59.94/29.97fps)
Lens	F No.	Wide: F1.6, Tele: F4.4
	Focal Length	Wide (x1) :4.5mm, Tele (x30) : 135mm
	Zoom	Optical Zoom 1~30times : Stepping Moter Digital Zoom 1~15 times : (Optical + Digital Zoom Max : 450 times)
	Focus	Stepping motor system auto focus Focus range : Wide 1.5m~ $\infty$ , Tele 1.5m~ $\infty$
	Optical Arange of view	Wide (x1) : D/61.7° , H/56.8° , V/32.8° Tele (x30) : D/2.5° , H/2.2° , V/1.2°
	Optical Filter	1: IR Cut Filter (for Day Color) 2: Through Glass
Video	Video Format	TMD5 : 1080p60/59/50/30/29/25, 1080i60/59/50, 1080PsF30/29/25, 720p60/59/50/30/29/25 EX-SDI : 1080p60/59/50/30/29/25, 1080i60/59/50, 1080PsF30/29/25, 720p60/59/50/30/29/25 3G-SDI : 1080p60/59/50 HD-SDI : 1080p30/29/25, 1080i60/59/50, 1080PsF30/29/25, 720p60/59/50/30/29/25
	Minimum Illumination	F1.5, Color 0.01 lx, B/W 0.005 lx, IR Cut Filter Off, AGC 42dB, 25IRE
	Signal to Noise Ratio	STD 52dB (Minimum 48dB)
Function	Setting	OSD, UART(2ch)
	Auto Iris	Yes
	Auto Exposure	Yes
	Auto Focus	Yes
	White Balance	Auto / Manual / Preset (One push)
	Manual Shutter	30fps : 1/30, 1/60, 1/120, 1/250, 1/500, 1/1000, 1/2000, 1/4000, 1/8000, 1/15000, 1/30000 25fps : 1/25, 1/50, 1/100, 1/200, 1/400, 1/800, 1/1600, 1/3200, 1/6400, 1/12800, 1/25600
	Sense Up	AGC Max 72dB & Slow Shutter Max 256 times.
	Day & Night Mode	Color / B&W / Auto / External
	Digital Noise Reduction	Yes
	Backlight Control	Yes
	Peak / Average Control	Yes
	Gamma Control	0.35 / 0.45 / 0.55 / 0.65 / 0.75 / 0.85 / 0.95 / Defog(L) / Defog(M) / Defog(H)
	Wide Dynamic Range	Yes
	Eclipse (High Light Clip)	Yes
	Fog Reduction	Yes
	Heat Haze Correction	Yes
	Motion Detection	Yes
	H/V Mirror, Flip	Yes
	OSD Language	English, Japanese, Korean, Chinese(Traditional), Chinese(Simplified)
	Title Display	Yes
Communication Protocol	GCC-CP / Pelco-D / Pelco-P / VISCA	
Privacy Mask	Yes (16 Masks)	
Preset Position	Yes (64 Area)	
Synchronous Mode	Internal	
General	Power Source	DC+12V
	Consumption Current	250mA (30fps)
	Operation Temperature	-10°C ~ +50°C
	Storage Temperature	-30°C ~ +70°C
	Humidity	80% Max
	Outside Dimensions	W48.8mm x H55.0mm x D93.1mm
Net Weight	230g	

**Global Chip Technology Corp.**

2-9-4-6F, Maruei-No.6 BLDG.

Minami-cho, Chuo-ku, Chiba-Shi

Chiba-Ken, Japan 〒260-0842

TEL : +81-43-308-6300

FAX : +81-43-261-6100

E-mail : info@gct-c.com

## Pin Assignment

JP401/901 (USL00-30L-A/KEL)		
1	GND in	Ground
2	TXCLKout-	TMDS Clock-
3	TXCLKout+	TMDS Clock+
4	GND in	Ground
5	TXout0-	TMDS TX0-
6	TXout0+	TMDS TX0+
7	GND in	Ground
8	TXout1-	TMDS TX1-
9	TXout1+	TMDS TX1+
10	GND in	Ground
11	TXout2-	TMDS TX2-
12	TXout2+	TMDS TX2+
13	GND in	Ground
14	485EN1	UART1 RS485 Enable output
15		Reserved
16		Reserved
17	Hot Plug Detect	5V.out, Open:stop
18	+5V Power	5V DC output
19		Reserved
20	GND in	Ground
21	I2CSCL	I2C Serial Clock
22	I2CSDA	I2C Serial Data
23	GND in	Ground
24	RX1	UART1 RX input
25	TX1	UART1 TX output
26	RESET	12V DC input
27	T12V in	12V DC input
28	T12V in	12V DC input
29	T12V in	12V DC input
30	T12V in	12V DC input

JP104/604 (53261-0671/MOLEX)		
1	DC12in	12V DC
2	GND	Power Ground
3	DC12in	12V DC
4	GND	Power Ground
5	IRext	ICR Control
6		Reserved

JP105/605 (SM06B-SRSS-TB/JST)		
1	ENTER	OSD Enter
2	RIGHT	OSD Right/Tele
3	LEFT	OSD Left/Wide
4	UP	OSD Up/Near
5	DOWN	OSD Down/Far
6	GND	Ground

JP107/607 (SM05B-SRSS-TB/JST)		
1	GND	Ground
2	TX2	UART TX (3.3V)
3	RX2	UART RX (3.3V)
4	DC33out	3.3V DC
5	485EN2	RS485 Enable (3.3V)

JP102/602 (AYU1-1P-02676-120/JST)		
1	EX-SDI	EX-SDI TX
2	GND	Video Ground

JP301/801 (SM04B-SRSS-TB/JST)		
1	DC33out	3.3V DC
2	ARin	Audio R
3	ALin	Audio L
4	AGND	Ground

(Option)

## Dimensions

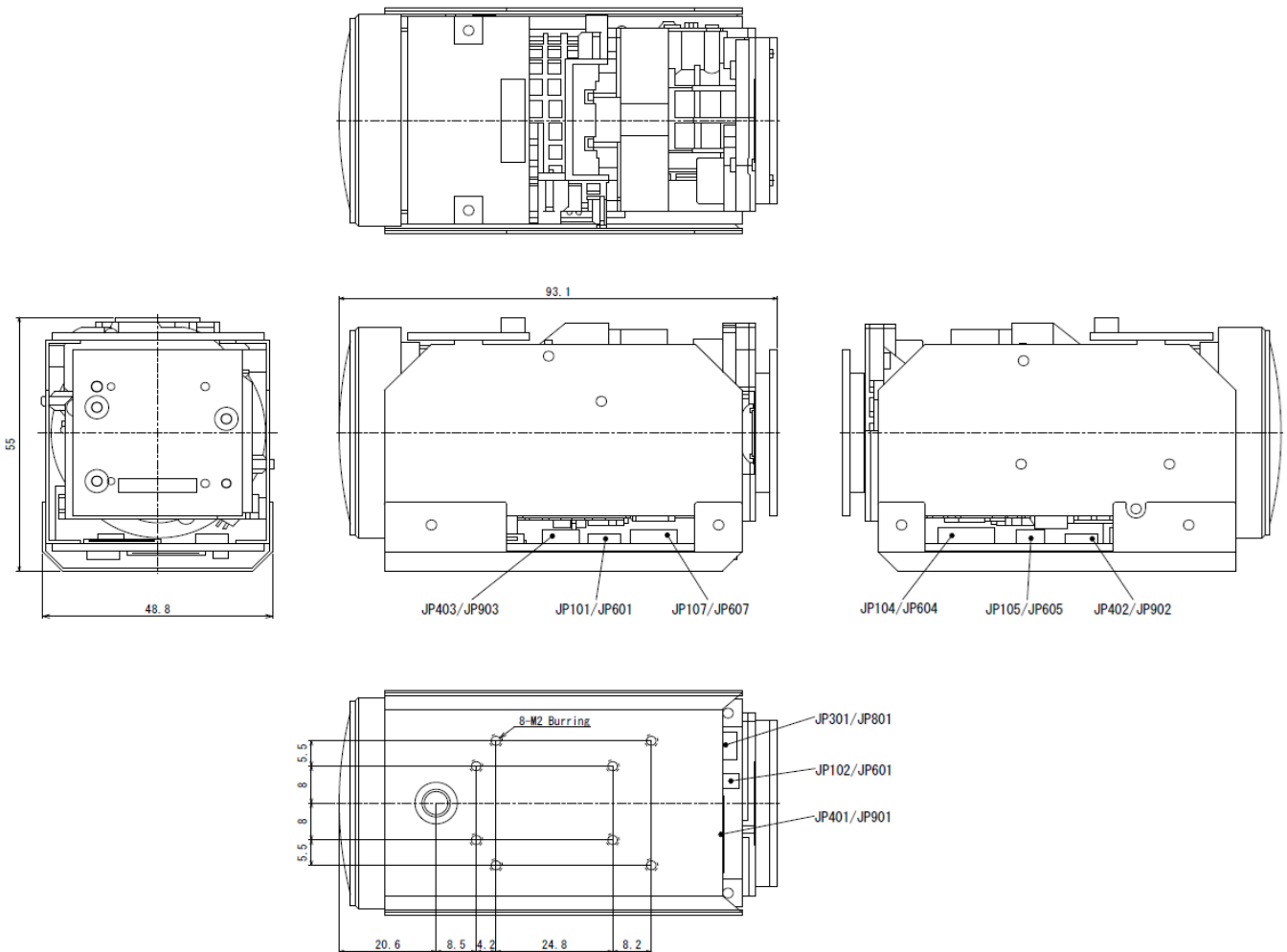

**Global Chip Technology Corp.**

2-9-4-6F, Maruei-No.6 BLDG.

Minami-cho, Chuo-ku, Chiba-Shi

Chiba-Ken, Japan 〒260-0842

TEL : +81-43-308-6300

FAX : +81-43-261-6100

E-mail : info@gct-c.com

■ OSD Menu

Menu	Parameter	Default	Range	
LENS	IRIS	MODE	AUTO, MANUAL	
		AUTO H-LIMIT	0-16	
		AUTO M-LIMIT	0-16	
		AUTO L-LIMIT	0-16	
		MANUAL LEVEL	0-16	
		INTERLOCK	OFF, ON	
	ZOOM	POSITION	----	----
		DZ-MODE	OFF	OFF, LINK, MANUAL
		DZ-LIMIT	X1	X1, X2, X4, X6, X8, X10, X12, X15
		DZ-MANUAL	200	0-400
		SPEED	2	0-4
	FOCUS	POSITION	----	----
		MODE	AFTER TELE	MANUAL, AUTO, INTERVAL, AFTER ZOOM, AFTER TELE, DIRECT
		ONE TIME AF	ON	↓
		SPEED	2	0-4
		INTERVAL	10sec	10sec, 30sec, 1min, 5min, 10min, 30min, 60min
	DAY&NIGHT	MODE	AUTO	AUTO, DAY, NIGHT, EXTERN
		D=>N LEVEL	13	0-24
		N=>D LEVEL	7	0-24
		DELAY	SLOW	SLOW, MIDDLE, FAST
	START UP	POSITION	----	DAY, NIGHT
		INITIALIZE	ON	OFF, ON
		MOVE	OFF	OFF, ON
	PRESET	PRESET No.	0	0-63
		No.	0	0-63
		SAVE	ON	↓
	DIS	LOAD	ON	↓
		MODE	OFF	OFF, ON
		RANGE	10%	10%, 20%, 30%
		LEVEL	HIGH	LOW, MIDDLE, HIGH
	EXPOSURE	AUTO CENTER	50%	OFF, 50%, 100%
		BRIGHTNESS	10	0-20
		SHUTTER	MODE	AUTO
AUTO H-LIMIT			1/15000	30fps : 1/30, 1/60, 1/120, 1/250, 1/500, 1/1000, 1/2000, 1/4000, 1/8000, 1/15000, 1/30000
AUTO M-LIMIT			1/1000	
AUTO L-LIMIT			1/30	25fps : 1/25, 1/50, 1/100, 1/200, 1/400, 1/800, 1/1600, 1/3200, 1/6400, 1/12800, 1/25600
MANUAL LEVEL			1/30	
SENS-UP		OFF	OFF, X1, X2, X4, X8, X16, X32, X64, X128, X256	
AGC		MODE	AUTO	AUTO, MANUAL
		PRIORITY1	IRIS>AGC	IRIS>AGC, AGC>IRIS
		PRIORITY2	AGC>SENS	AGC>SENS, SENS>AGC
		AUTO LIMIT	72dB	0-72dB
		MANUAL LEVEL	0dB	0-72dB
		AUTO GAMMA	OFF	OFF, LOW, MIDDLE, HIGH
		AUTO SETUP	10	0-20
POSITION		----	----	
PEAK-AVE		10	0-20	
BACKLIGHT		MODE	OFF	OFF, ON
		H-POSI	16	0-38
		V-POSI	12	0-35
		H-SIZE	6	0-38
		V-SIZE	10	0-35
ECLIPSE		MODE	OFF	OFF, ON
		LEVEL	10	0-20
		COLOR	BLACK	WHITE, YELLOW, CYAN, GREEN, MAGENTA, RED, BLUE, BLACK
WDR		MODE	OFF	OFF, ON
		LEVEL	HIGH	LOW, MIDDLE, HIGH
COLOR		WB	AUTO	MANUAL, AUTO, AUTO-EXT, PRESET
		MANUAL TEMP	5000K	3000K, 5000K, 8000K
		R-GAIN	10	0-20
		B-GAIN	10	0-20
		COLOR GAIN	10	0-20
		SUPPRESS	0	0-10
	BLACK ADJUST	NIGHT	OFF, ON, COLOR, NIGHT	
	NIGHT COLOR	OFF	OFF, ON	

**Global Chip Technology Corp.**  
 2-9-4-6F, Maruei-No.6 BLDG.  
 Minami-cho, Chuo-ku, Chiba-Shi  
 Chiba-Ken, Japan 〒260-0842  
 TEL : +81-43-308-6300  
 FAX : +81-43-261-6100  
 E-mail : info@gct-c.com

Menu	Parameter		Default	Range	
IMAGE	SHARPNESS		5	0-10	
	DNR		HIGH+	OFF, LOW, LOW+, MIDDLE, MIDDLE+, HIGH, HIGH+	
	HEAT HAZE		OFF	OFF, LOW, MIDDLE, HIGH	
	DWDR		OFF	OFF, LOW, MIDDLE, HIGH	
	DEFOG	MODE	OFF	OFF, MANUAL, AUTO	
		LEVEL	MIDDLE	LOW, MIDDLE, HIGH	
	GAMMA		0.45	0.35, 0.45, 0.55, 0.65, 0.75, 0.85, 0.95, DEFOG-L, DEFOG-M, DEFOG-H	
	PRIVACY	NO.	0	0-15	
		DISPLAY	OFF	OFF, ON	
		H-POSI	12	0-60	
		V-POSI	2	0-34	
		H-SIZE	3	0-60	
		V-SIZE	3	0-34	
		Y-LEVEL	10	0-20	
		CB-LEVEL	10	0-20	
		CR-LEVEL	10	0-20	
	TR-LEVEL	0	0-3		
MIRROR		OFF	OFF, ON		
FLIP		OFF	OFF, ON		
FREEZE		OFF	OFF, ON		
COLORBAR		OFF	OFF, ON		
SYSTEM	COMM	CAMERA ID	0	0-63	
		BAUDRATE	115200	2400, 4800, 9600, 19200, 38400, 57600, 115200	
		PROTOCOL	GCC-CP	GCC-CP, PELCO-D, PELCO-P, VISCA	
		PORT	1	1, 2	
	VIDEO	FRAMERATE	30/60Hz	30/60Hz, 25/50Hz, (Option 29.97/59.94Hz)	
		FORMAT	1080p 30	30/60Hz : 720p30, 720p60, 1080p30, 1080p60, 1080i60, 1080PsF30 25/50Hz : 720p25, 720p50, 1080p25, 1080p50, 1080i50, 1080PsF25 29/59Hz : 720p29, 720p59, 1080p29, 1080p59, 1080i59, 1080PsF24	
		SDI MODE	HD-SDI	OFF, HD-SDI, 3G-SDI, EX-2.0 135M, EX-2.1 135M, EX-3.0 135M,	
		SDI EMPHASIS	OFF	OFF, ON	
		TMDS MODE	RGB	OFF, RGB, YCbCr	
		IMAGE RANGE	FULL	FULL, COMP	
		COLOR SPACE	HD-PbPr	YUV, SD-CbCr, HD-PbPr	
	CONFIRM	ON	↓		
	AUDIO		OFF	OFF, ON	
	LANGUAGE		ENGLISH	ENGLISH, JAPANESE, KOREAN, CHINESE(T), CHINESE(S)	
	TITLE	CAM TITLE	OFF	OFF, ON	
		TIME CODE	OFF	OFF, ON	
		POSITION	TOP-R	TOP-R, TOP-L, BOTTOM-R, BOTTOM-L	
	MOTION	MODE	OFF	OFF, ON	
		WINDOW	No.	0	0-3
			USE	ON	OFF, ON
			H-POSI	0	0-30
			V-POSI	0	0-17
			H-SIZE	30	0-30
		V-SIZE	16	0-17	
	SENSITIVITY	5	0-5		
	DISPLAY	OFF	OFF, ON		
	TEXT ALARM	OFF	OFF, ON		
VERSION	S/N	----	----		
	FIRMWARE	----	----		
	VERSION	----	----		
RESET		ON	↓		

**Global Chip Technology Corp.**

2-9-4-6F, Maruei-No.6 BLDG.

Minami-cho, Chuo-ku, Chiba-Shi

Chiba-Ken, Japan 〒260-0842

TEL : +81-43-308-6300

FAX : +81-43-261-6100

E-mail : info@gct-c.com